

comscoot  
commute and scoot

**USER MANUAL AND  
SERVICE BOOK**  
comscoot performance



Dear comscoot performance buyers and users,

you have made a good choice with your decision to buy an e-scooter from comscoot. Thank you very much for that.

First of all, we would like to give you important information about your new comscoot performance. This should help you to understand your newly acquired vehicle, to make use of the various possibilities and to avoid risks.

As the owner of the comscoot performance, please keep the manual and in case of resale, give it to the buyer. These operating instructions are an integral part of your comscoot.

If safety-relevant changes are made to the operating instructions, these will be taken into account in a new edition, which will be made available for download immediately at [www.comscoot.com](http://www.comscoot.com).

Your comscoot performance can be assembled in just a few steps and is thus quickly ready for use. However, we recommend having the assembly carried out by an authorised specialist dealer.

**Please read these operating instructions very carefully and consult your authorised dealer if you do not understand individual points. This is for your own safety and that of all other road users. Failure to observe these operating instructions can lead to serious accidents and cause severe damage. These instructions apply to the model "comscoot performance".**

Your comscoot performance complies with the regulations for participation in public road traffic in the Republic of Austria. It is mandatory to observe the corresponding and respectively valid regulations. If you want to use the comscoot performance in a country other than Austria, please always check whether this is legally permissible.

### SAFETY INSTRUCTIONS

Riding a comscooter can be fundamentally dangerous. Just like a bicycle, the comscooter has no protective devices like a motor vehicle protected by a body and other components. However, due to the motor assistance of the comscoot performance, you are usually faster than a pedestrian and, as a rule, also faster at the start than a conventional bicycle without electric drive. Therefore, always ride carefully and considerably so as not to obstruct or endanger other road users.

This manual is designed to help you understand the proper use and maintenance of this electric scooter.

**It is important that you understand your new e-scooter and its functions and how to use it so that you can handle it safely from the first ride.**

We recommend that you take your first ride with the comscoot performance in a place without obstacles and familiarise yourself with the functions and driving style. Statistically proven, most accidents with e-scooters happen during the first rides. Before each ride, make sure that all connecting parts and especially the folding lever for locking the handlebars are firmly locked.

#### Also observe the following safety instructions:

- Always wear a suitable and approved helmet and close-fitting clothing when riding the comscoot performance.
- Do not wear dark clothing and use clothing with attached reflectors. This increases your safety and that of other road users enormously.
- Always follow local laws and regulations. This includes that you observe the limits for the consumption of alcoholic beverages, etc.
- If possible, do not drive in poor visibility and bad weather. This can increase your braking distance. Always adjust your speed in good time.
- Do not do any stunts, wheelies or jumps and never ride freehand. You increase your risk of injury and possibly damage your comscoot performance.
- E-scooters are only permitted for one person. Do not carry passengers or animals.

- Never ride barefoot or in light footwear. Use shoes with a firm, slip-resistant sole.
- Tall people in particular must be especially careful when driving under obstacles.
- Do not talk on the phone while driving your comscoot performance.
- If persons under the age of 18 drive the comscoot performance, they must be made particularly familiar with the handling and use of the comscoot performance. In doing so, they must be made aware of the dangers in road traffic for themselves and for other road users. The comscoot performance has a battery-powered drive. The corresponding dangers must be pointed out.

Your comscoot performance may only be used as intended. You may only use your comscoot performance if it is in perfect working order. Tuning measures make your comscoot performance unfit for driving in public road traffic. The comscoot performance may only be driven by persons who have sufficient physical and mental capabilities.



**Table of content:**

Safety Instructions	page 04
Scope of Delivery	page 09
Finished Assembly	page 12
Fold and Unfold	page 14
Security Check	page 15
Driving Instructions and Technique	page 17
Battery	page 19
Lighting	page 24
LCD display and Functions	page 25
comscoot App	page 27
Care and Maintenance	page 29
Inspection Records	page 31
Maintenance Plan	page 32
Vehicle Identification	page 35
Technical Data	page 36
CE Declarations of Conformity	page 37

## Read these operating instructions very carefully!

- This instruction manual is designed to help you understand the proper use and maintenance of this electric scooter.
- It is important that you understand your new scooter and its functions and how to use it so that you can handle it safely from the first ride. Read through these operating instructions before your first ride and repeat this after a longer period of non-use. If you give your comscoot performance to other persons for use, hand over these operating instructions to them and point out that they must be observed.
- We recommend that you take your first ride with your comscoot performance in a place without obstacles and familiarise yourself with the functions and driving style.

## Before each ride, make sure that all connecting parts and especially the folding lever are firmly locked.

- You as the owner and as the driver are responsible for the maintenance of the comscoot performances and the equipment in accordance with the general operating permit. In this regard, also observe the notes regarding the recommended service intervals. Proper maintenance helps to avoid accidents due to material fatigue, etc., which cannot be ruled out, and thus reduces a possible risk of injury.
- Read these operating instructions very carefully and always observe the instructions contained herein. Important passages in these operating instructions are marked accordingly in bold or by warning words.
- In detail, these can be the following indications:

 **CAUTION**

 **ATTENTION**

 **ACCIDENT HAZARD**



The seller of the comscoot performances is not liable for any damage incurred in connection with the use of the comscoot performances.

## ASSEMBLY

Read all instructions in this operating manual completely before assembly.





## SCOPE OF DELIVERY

Before installation, carefully check the entire scope of delivery for completeness. If anything is missing or obviously defective, please contact your authorised dealer.

**Representation of the assembled comscoot performances:**

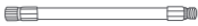

**The scope of delivery includes the following parts:**

valve extension	4 screws (M5 x 10 mm)	spanner
		
charger	operating instructions	
		

**comscoot performance complete overview**

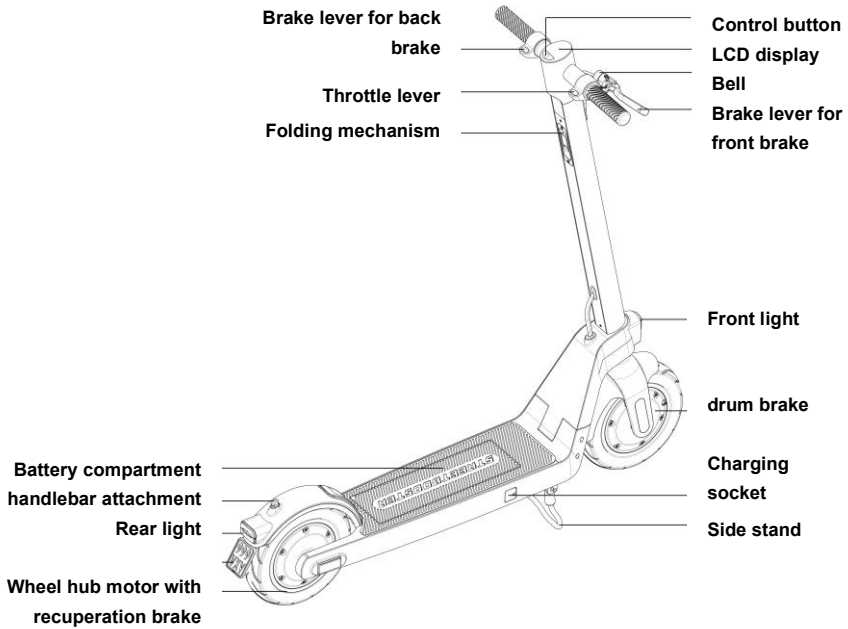

## FINISHING ASSEMBLY

If you have not purchased your comscoot performance from a specialist dealer, it will not be delivered fully assembled. Therefore, please observe the following instructions very carefully. Proper assembly is relevant to safety and should always be carried out by an authorised specialist dealer. If, for whatever reason, you carry out the assembly yourself, please make sure that it is carried out exactly in accordance with these operating instructions.

For transport and packing purposes, the handlebar of the comscoot performances is dismantled. Unpack it very carefully. The connecting lines mounted on the handlebar are connected to the steerer tube. The components must not be stretched or pulled apart, as otherwise important connecting parts can become loose or, in the worst case, tear off.

1. Insert the handlebar into the steerer tube.

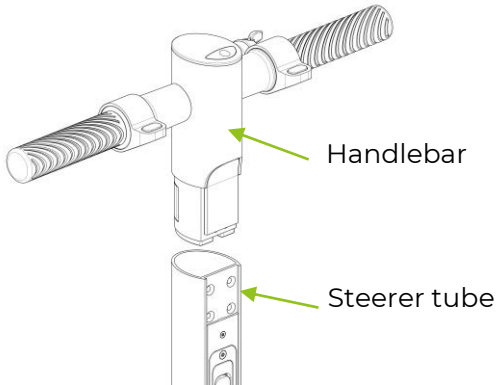

2. Secure the handlebar with the supplied bolts using a torque spanner. The tightening torque for the screws is 5 NM.

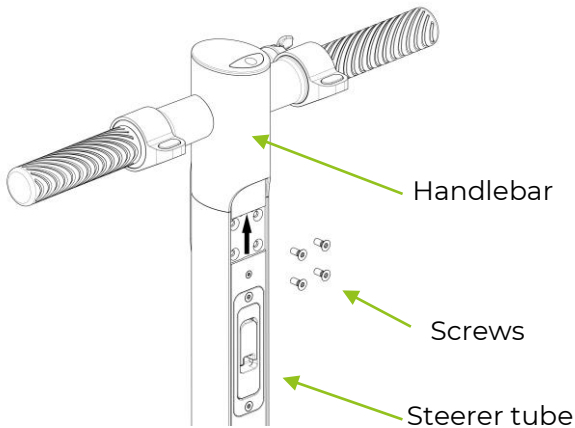

**⚠ CAUTION:** The supplied spanner is only for pre-assembly. The screws must be tightened to the specified torque using a torque spanner.

## Folding and unfolding the comscoot performance

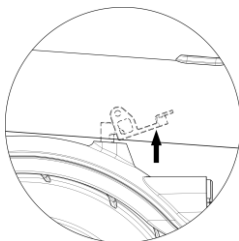
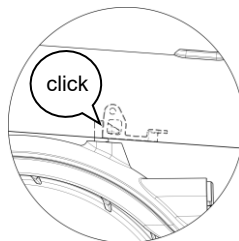
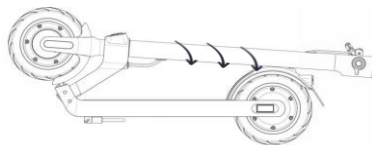
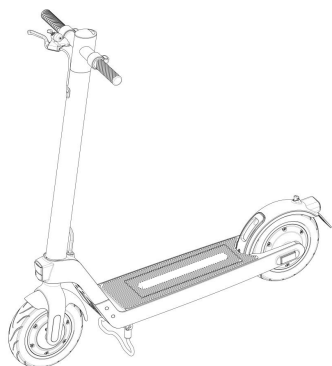

Make sure that your comscoot performance is switched off. To fold it, unlock the folding mechanism (first 1, then 2) and bend the handlebar stem. Then snap it into place on the rear mudguard. To open, pull the tab (3) on the rear hooking device on the mudguard. Now you can set up the handlebars and lock the folding mechanism.

**⚠ ACCIDENT HAZARD:** After each assembly, make sure that the lock is firmly tightened

## SAFETY CHECK

**Read the safety check instructions very carefully. Before each journey, the assembly and especially the unfolding and closing of the folding mechanism must be checked very carefully.**

### BEFORE USING THIS comscoot performance:

- Carry out a visual inspection. Check that all screws and nuts are tight. Note if anything looks wrong or shows signs of wear. If you are not sure, take your scooter to an authorised dealer for inspection.
- **TYRES AND WHEELS:**  
Check the tyres for wear. Make sure the wheels turn freely from the brakes. Fill the tyres with the prescribed air pressure. This must be between 3.0 and 3.4 bar. If you find any defects, take your comscoot performance to an authorised dealer for inspection.
- **BRAKES:**  
Check the brakes of your comscoot performance before every journey. Before you set foot on the comscoot performance, apply the rear wheel brake so that the comscoot performance does not roll away unintentionally.  
Test the brakes before and during each ride to ensure they are working properly. Before driving off, fully apply the rear wheel brake. When you push the comscoot performance forward, the rear wheel must lock. Test the front wheel brake with the engine switched on and at a low driving speed between 4 and 7 km/h. To do this, press the brake lever with

the hand wheel. To do this, press the brake lever completely down with your left thumb. Your comscoot performance should come to a stop after a maximum of three metres. If you are not sure whether full braking performance is achieved, take your comscoot performance to an authorised dealer for inspection.

## BATTERY STATE OF CHARGE:

- Fully charge the battery of your comscoot performances before the first ride. To do this, follow the instructions for charging the battery in this operating manual. Before each further planned journey, make sure that the battery's state of charge is sufficient for the planned journey.



### DRIVING INSTRUCTIONS:

- Familiarise yourself with the e-scooter before you ride it. Test your control over it. Drive slowly and carefully in curves and always keep a safe distance from obstacles of any kind.
- Train your driving skills: To gain and maintain control of your comscoot performance, practice your first ride in an area without obstacles. Even after a longer period of non-use, we strongly recommend doing some practice rides in an open area without obstacles.
- Before driving off, you must switch on the comscoot performance. To do this, press and hold the control button for two seconds.

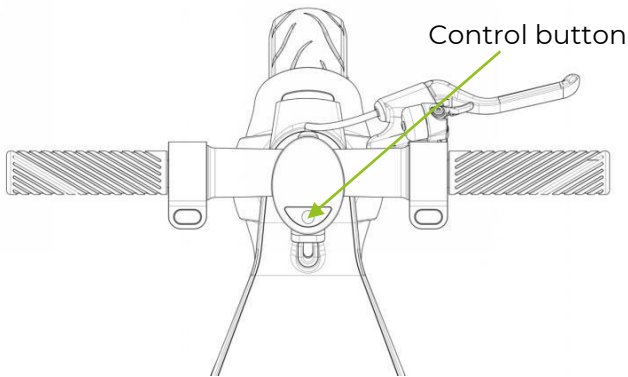

### DRIVING TECHNIQUES:

- Fold up the parking support with your foot and check that it cannot come loose while driving. **⚠ ACCIDENT HAZARD:** Do not drive with the parking support folded down! This can lead to accidents with serious injuries.
- Before each journey, check both brakes as previously described.
- Before starting off, apply the rear wheel brake so that your comscoot performance does not move unintentionally.
- Before starting, place your foot as close as possible to the front of the scooter and the other foot on the ground.
- Make sure that your driving lane is clear.

- Drive only on dry, ice-free and unpolluted roads.
- Release the brake.
- Push the scooter forward with your foot on the ground (as with non-motorised pedal scooters). After pressing the throttle on the right side of the handlebar, tilt your body slightly forward so that you do not fall backwards during acceleration.
- Always press the throttle carefully and adapted to the respective traffic situation. This will help you avoid accidents.
- When you brake, tilt your body slightly backwards and the scooter will slow down or stop.
- Your comscoot performance has two brakes. You use the mechanically acting rear wheel disc brake with the brake lever on the right of the handlebar. You use the electronic brake with the thumb lever on the left of the handlebar.
- If the road is dirty, damp or wet, the braking distance is longer and there is an increased risk of an accident. Slow down in such conditions. Always adapt your speed to the respective weather and traffic situation.
- When driving downhill, your comscoot performance can reach a higher speed than 25 km/h. Slow down your comscoot performance to the maximum speed in good time.
- When driving downhill, apply the brakes at intervals to prevent the brake systems from overheating.
- Avoid the body pressing on the handlebars when accelerating and braking.
- Put one foot behind the other. It is more comfortable to place one foot forward and turn the other 70-90 degrees. This will give you greater balance and stability when riding.
- The handlebars should be parallel to the body when making long turns. You ride long curves by shifting your weight in the direction of the curve. When doing this, ride carefully and do not lean too hard into the curve.
- When cornering at a slow walking speed, carefully turn the handlebars in the desired direction. Before cornering, make sure that other road users are not obstructed and that there are no obstacles in the way. Your comscoot is equipped with a bell on the right handlebar. You operate it with your right pointer finger.

**⚠ CAUTION:**

- When riding, risks of injury cannot be excluded and damage is possible. When you ride the comscoot performance, you are responsible for all associated risks.

**It is important that you fully know, understand and act upon these safety rules.**

**SUSPEND:**

- Your comscoot performance has a side stand. You can fold it out and in with your foot. To park, press the side stand down with your foot. Only park your comscoot performance on firm ground.

**BATTERY:**

- **Your comscoot performance is equipped with a high-performance battery. The handling and use of a battery is associated with dangers and can lead to serious damage and accidents if handled improperly. Therefore, follow the instructions very carefully.**
- The battery is permanently installed in your comscoot performance. Never attempt to remove or even open it. These tasks are to be carried out exclusively by the authorised specialist dealer.

### ⚠ ATTENTION:

- **Do not operate the comscoot performance during the charging process.**
- Do not store the comscoot performance for a longer period of time with a fully charged battery. If the comscoot performance is not used for more than one month, charge it to half.
- Discharge the battery completely from time to time by driving the comscoot performance empty with all the energy stored in the battery.

### DO NOT USE THE BATTERY:

- If the comscoot performance is defective or has had an accident. Any strong impact can lead to a deformation of the battery. This can lead to the leakage of liquids, fire or an explosion. The battery's safety electronics may fail.
- If there is an unusual odour.
- If it has been exposed to excessive heat.
- If there is visible leakage of liquids.
- If an unusual odour develops, vapours are produced or liquids leak out, switch off your comscoot performance immediately. Immediately disconnect your comscoot performance from the charger and this from the power supply. If your comscoot performance is in a closed room, ventilate it immediately and sufficiently.
- Avoid contact with substances that may leak from the battery at all costs. These can cause eye and skin irritation. In the event of such contact, consult a doctor immediately. In case of eye irritation, rinse your eyes immediately with plenty of cold water.
- Never use the battery without having it checked by an authorised dealer if you or others experience any of the incidents described above.
- **If the battery of your comscoot performances starts to smoke, disconnect the power supply immediately and call the fire brigade without delay. Never try to extinguish damaged batteries with water.**

### ⚠ CAUTION:

- Keep the battery away from children and pets.

- Touching live parts on the battery can cause death or serious injury.
- Put your comscoot performance out of operation after a fall or severe impact and observe the battery for at least 24 hours.

#### **PROPER STORAGE AND USE OF THE BATTERY:**

- Avoid exposure to intense heat, including sunlight above 35 degrees Celsius.
- Never bring the battery into contact with metal parts of any kind. This may cause short circuits resulting in fire or explosion. This in turn can result in serious injury or damage.
- Protect the battery from moisture caused by liquids of any kind. This can lead to short circuits and the consequences described above.
- Never clean your comscoot performance with a high-pressure cleaner. Use a damp cloth and suitable, mild cleaning agents.
- Always store your comscoot performance in a dry and well-ventilated place.
- If the battery is not used for a longer period of time, charge it about halfway and check the charge level about every 4-5 weeks. This will increase the useful life of your battery.
- Be sure to avoid a complete discharge over a longer period of time. Such a deep discharge can cause considerable damage to the battery and even render it completely unusable. Recharge the battery within 48 hours after a deep discharge.

Use, storage or charging of this battery outside the specified instructions may void the warranty, damage the battery and charge the battery ineffectively.

**If you remove or open the battery yourself, this may result in the loss of warranty & guarantee claims.**

#### **CHARGING THE BATTERY**

##### **Information**

- Your comscoot performance may only be charged with the external charger supplied and approved for this purpose.
- The battery may only be charged in a dry and clean environment.
- Neither the battery nor the charger may overheat during the charging process. A temperature of more than 45 degrees must not be exceeded.

**comscoot GmbH**  
AT-8403 Lebring, Südbahnweg 17-19

info@comscoot.com  
www.comscoot.com

Departments:  
COMMUTE, SHARING, TOURISM, SALES ... commute and scoot

FN: 569864k; UID: ATU77595826  
HK: Graz  
Registered office: St. Andrä-Höch

Management:  
Philipp OSWALD  
Georg SCHNABEL

Tel.: +43 (0) 664 750 620 50  
Tel.: +43 (0) 664 47 90 802

Confidentiality class: public  
Copyright © 2022 comscoot GmbH  
**page 21 of 40**

- Make sure that the contacts of the charging cable and the charging socket are dry.
- Make sure that the charger is placed on a fireproof surface and is not covered.
- Disconnect the charger from the mains again after charging.

**THE CHARGING PROCESS:**

- To charge, connect the charging cable to the charging socket of the comscoot performances. The charging socket is located at the front left of the footboard.

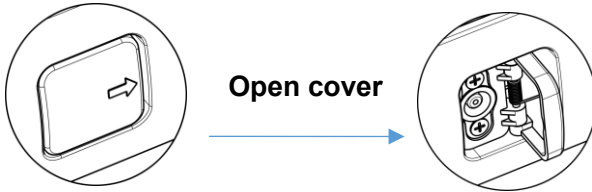

- First connect the power cable of the charger to a socket and then connect the other end to the charging socket of the comscoot performances.
- If the charging indicator light lights up red, the battery is being charged.
- If the charging indicator light is green, the battery charging process is complete.
- Avoid spending too long (more than 4-5 weeks) with an uncharged or fully charged battery. To maintain the battery's performance, charge it once within this period, about halfway.
- It takes about 4-5 hours to fully charge the battery.
- Close the charging socket again when charging is complete.

**⚠ ATTENTION:**

**It is dangerous to work on the comscoot performance when it is connected to a mains socket. An electric shock can cause serious injuries and damage the comscoot performance. To maintain the full warranty, maintenance work must only be carried out by an authorised specialist dealer.**

**Never try to open the battery. Do not insert anything into the battery and never try to insert anything into the battery. Inserting an object into openings or into the battery may cause an electric shock, damage the battery and cause the release of dangerous toxins.**

**EN**

## DISPOSAL OF THE BATTERY:

- Batteries are hazardous materials. Dispose of batteries properly and never as residual waste. You can return the battery of your comscoot performances to us free of charge.

## ENGINE:

- A maintenance-free, brushless DC motor is installed in your comscoot performance. This is located in the front wheel.
- The motor has an overheating protection. In case of overheating, the motor switches off and after a few minutes of cooling down, you can drive again.

## ⚠ CAUTION:

**The engine can become very hot when heavily loaded or when driving uphill. Avoid touching the engine at all costs. There is a risk of injury.**







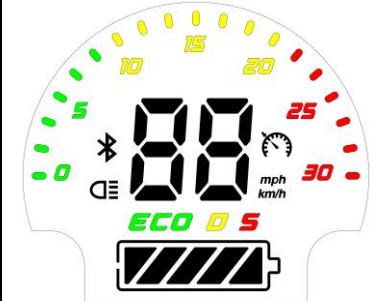

## LIGHTING:

- Your comscoot performance is equipped with high-quality LED lighting. Clean it regularly with a damp cloth and mild cleaning agents. The lighting is supplied with energy from the battery. For your safety and that of all other road users, switch on the lighting in poor visibility conditions, twilight and darkness.
- Modern LED lamps must be replaced as a whole if they are defective. Contact an authorised specialist dealer in case of defects or adjustments.



## LCD DISPLAY

Your comscoot performance has an LCD display that shows all important information.

		Current performance range
		Current speed
		Bluetooth connection active
		Light switched on
		Battery charge level display
		Cruise control
		Driving modes

## OPERATION

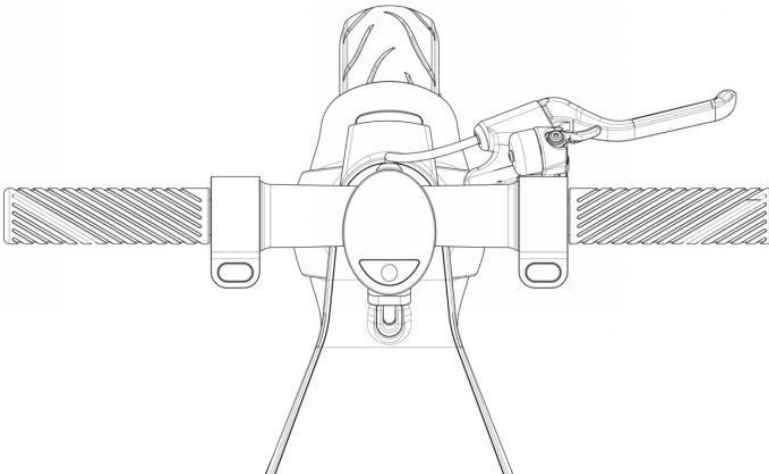

EN

## Switching the e-scooter on / off

- When the scooter is switched off, press the control button to switch the comscooter on.
- With the comscooter switched on, press and hold the control button for 2 seconds to switch the scooter off.

## Switch on / switch off light



Switch on the light: When your comscoot performance is switched on, press the control button once to switch on the light. Press it again to switch it off.

## Driving modes

The various driving modes can be set by pressing the control button quickly twice.

As soon as the **S** appears on the display, you are in sport mode and you can call up the full speed.

When the **N** appears on the display, you are in normal mode and can drive up to 20km/h.

When **ECO** appears on the display, you are in ECO mode and you can drive the scooter at speeds of up to 12 km/h.

## Cruise control function

After pressing the control button three times, the cruise control activates. After two beeps, the cruise control is activated and you can take your thumb off the throttle. As soon as you brake or accelerate, the cruise control is automatically deactivated.

## comscoot App

You can connect to your comscoot performance with a smartphone via Bluetooth. The app must be installed manually on an Android or iOS smartphone. The app can be downloaded and installed from

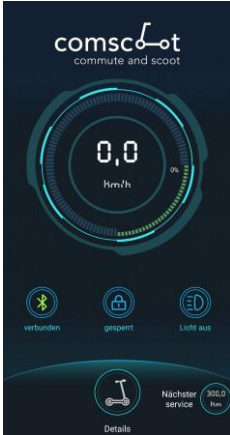

the Google Play Store and also from the Apple Store. (Available from Q2 2022)

Switch on your e-scooter. You can then start the app. The app will search for available devices when it starts. Please select your e-scooter (designation may differ) by tapping on it. Please enter the password of the e-scooter (888888 after delivery). The e-scooter is now connected. The user interface of the app then appears.

HW\_UG001470  
AC:23:3F:41:B9:7D

Connecting the  
Bluetooth



### **⚠ ATTENTION:**

Please change the password immediately under Details and Change password. Otherwise, strangers can gain access to your e-scooter and deactivate the drive-away lock, among other things!



If the 'Available devices' dialogue does not appear and the user interface and the e-scooter are not connected, tap on 'Not connected' and the 'Available devices' dialogue opens.

The next time the app is started, it automatically connects to the e-scooter and the user interface appears immediately after the password is entered. Only one smartphone can be connected to the e-scooter at a time.

**NE**



There are three buttons to tap below the speed indicator. Bluetooth connection, immobiliser and light.



When active, these are green, otherwise blue (Bluetooth) and white.

If you have the immobiliser active, the front wheel locks and the e-scooter cannot be driven and is difficult to push. The immobiliser also remains active when the app is closed. The e-scooter cannot be switched off by pressing the button when the immobiliser is active.



This shows when the next service is due for the e-scooter. Please take your e-scooter to a comscoot performance specialist dealer for inspection when the remaining kilometres displayed are approaching zero. After the inspection, the specialist dealer will reset the remaining kilometre display.

Under Details you can view further technical data of the e-scooter and change the language of the app. You can also change the password of the e-scooter here.

### Battery charge indicator

Your comscoot performance has a battery charge indicator consisting of five sections. The battery is fully charged when all five sections are displayed. If only one section is displayed, there is only a small charge capacity left. The supply of energy to your comscoot performances will stop very soon if you continue to use it.

**⚠ CAUTION:** A completely discharged battery will also cause the lights to stop working.

**⚠ ACCIDENT HAZARD:** You will not be noticed by other road users if your lights are switched off or not working and you can no longer illuminate your path of travel. There is a high risk of accidents, which can result in the most serious injuries and damage.

## ONGOING CARE AND MAINTENANCE

- Your comscoot performance contains high-performance components that require ongoing care and regular maintenance. This is the only way you can use your comscoot performance reliably for a very long time.
- Clean your comscoot performance after every ride with a damp cloth and mild cleaning agents.
- If you notice damage of any kind during cleaning, have it repaired immediately by an authorised specialist dealer.
- Never use a high-pressure cleaner for cleaning.

**⚠ CAUTION: Various parts may wear out or you may suffer a defect. This can lead to accidents and serious damage.**

- Have your comscoot performance checked regularly by an authorised specialist dealer.
- Only original and approved spare parts and components may be used.
- If you use non-approved parts, the full functionality and safety of your comscoot performance can no longer be guaranteed. This can lead to the loss of warranty and guarantee claims.

**⚠ CAUTION:** If you want to work on your comscoot performance, always switch it off first. The comscoot performance must not be connected to the charger during any work.

Make sure that you do not touch any live parts and only have maintenance and servicing work on such parts carried out by an authorized specialist dealer.

**Please check the following components regularly at least once a week:**

- Check tyres for wear and proper pressure. The tyre pressure must be between 3.0 and 3.4 bar.
- The rims must not show any damage. Rims are safety-relevant parts which, if defective, can lead to serious accidents and damage.
- The functional check of the brakes was described in the chapter on driving instructions. Disc brake systems are subject to wear during use. Visually inspect the rear brake pads and the brake disc at least once a week. If you notice any changes that deviate from the

normal condition, have the brakes of your comscoot performances checked immediately by an authorised specialist dealer and replace them if necessary.

### Regular inspections by an authorised dealer

- Your own and regular checks and inspections of your comscoot performances do not replace regular inspections by authorised specialist dealers!
- Mechanical connections can become loose or cables can become jammed and thus no longer function.
- If inspections are not carried out in accordance with the specifications, this can lead to the loss of the warranty or guarantee if it is found that any faults that occur could have been avoided by an inspection.

**INSEPTION PROOFS:**

In your own safety interest and to preserve your warranty and guarantee claims, make sure that the following inspection intervals are observed:

1. Inspection										
to 250 km										
Date:					2	0				
Mileage:		●		●						
Dealer stamp and signature										

2. Inspection										
1. Year (latest at 3.000 km)										
Date:					2	0				
Mileage:		●		●						
Dealer stamp and signature										

3. Inspection										
2. Year (latest at 6.000 km)										
Date:					2	0				
Mileage:		●		●						
Dealer stamp and signature										

4. Inspection										
3. Year (latest at 9.000 km)										
Date:					2	0				
Mileage:		●		●						
Dealer stamp and signature										

5. Inspection										
4. Year (latest at 12.000 km)										
Date:					2	0				
Mileage:		●		●						
Dealer stamp and signature										

6. Inspection										
5. Year (latest at 15.000 km)										
Date:					2	0				
Mileage:		●		●						
Dealer stamp and signature										

EN

## MAINTENANCE PLAN:

Area	Work to be carried out professionally
Frame	Check the frame and steerer tube externally for visible deformation and cracks
	Check all connections with correct tightening torques
Handlebar	Check the handlebars externally for visible deformations and cracks
	Check correct tightening torques of the handlebar screw connections
	Check the handles for wear and replace them if necessary
Wheels	Check installation positions and fastening
	Check tyres for wear and replace if necessary.
	Check tyre pressure
Folding mechanism	Check rims for damage and correct concentricity
	Check the folding mechanism for proper function
	Check quick release for proper function and lubricate properly. Lubricate as required
Parking support	Check for safe function
Brakes	Check brake system including brake lever for function and fastening
	Check and clean brake pads and brake disc
	Check Bowden cable
Lighting system	Check the complete lighting system
	Adjusting the front light correctly
	Check jam-free cable routing
LCD display	Check the functionality of the LCD display
Electronics	Check for current software version and update if necessary
Function test	Check all driving modes
	Check cruise control
	Check recuperation brake
	Check all switches and levers
Bell	Check bell for proper function
Test drive	Final check (check for unusual noises, check driving behaviour)
Battery	Check the self-protection safety mechanisms of the battery
	Check the battery and connections for damage
Charger	Check for proper function





**⚠ ATTENTION - IMPORTANT NOTICE:**

If you have not purchased your comscoot performance from an authorised specialist dealer, you are nevertheless obliged to follow and comply with all assembly and maintenance instructions. Your warranty and guarantee claims may otherwise be limited, especially if it can be proven that the installation or maintenance was faulty or insufficient.

Always observe the warnings in these operating instructions and comply with the applicable road traffic regulations when operating.

Your comscoot performance is designed for a maximum total weight of 120 kg. Never exceed this.

**VEHICLE IDENTIFICATION:** (please be sure to fill in)

<b>Chassis number</b>											
<b>Purchase date</b>							2	0			
<b>Purchase</b>	yes	<input type="checkbox"/>									
	no	<input type="checkbox"/>									
<b>Loan unit</b>	yes	<input type="checkbox"/>									
	no	<input type="checkbox"/>									

Keep your proof of purchase in a safe place. Warranty or guarantee claims are void without presentation of the original proof of purchase.

**TUNING PROHIBITION**  **CAUTION,**  **ACCIDENT HAZARD**

**Tuning your comscoot performances is prohibited and poses a high safety risk.**

- The components of your comscoot performances are designed for the performance specifications shown in these operating instructions.
- If you tune your comscoot performance, this may result in the loss of insurance cover and the invalidation of warranty and guarantee claims.
- If accidents are attributed to tuning measures, this may lead to personal liability and criminal prosecution.

## TECHNICAL DATA (valid for: Austria, as of January 2022)

Technical data	Description	Specifications
Dimensions	Assembled (length x width x height) in cm	114 x 45 x 117
	Folded (length x width x height) in cm	119 x 45 x 39
Empty weight	in kg	approx. 20
Maximum weight	in kg	140
Requirements for the driver	Weight in kg	approx. 25 bis 120
	Age in years	12+ (with bike pass from 9 or 10 years)
	Body height in cm	approx. 120 to 200
Performance data	Maximum speed in km/h	25
	Maximum range in km	33
	Maximum slope in %	20
Wheel hub motor with recuperation brake	Normal power in watts	450
	Newton metre	22
7.8 Ah lithium-ion battery	Operating voltage in volts	42
	Capacity in Wh	360
	Intelligent battery management system with shutdown in case of	<ul style="list-style-type: none"> <li>• Unusual temperature</li> <li>• Short circuit</li> <li>• Over- and undervoltage</li> <li>• Overcharge protection</li> <li>• Undercharge protection</li> </ul>
Charger	Charging power in watts	84
	Charging power in amps	1,7 ± 0,2
	Input voltage in volts	100 - 240
	Rated voltage in volts	42
	Charging time until fully charged in hours	ca. 4,5
	Charging time to approx. 80% in hours	ca. 2,5
Display	Technology	LCD
	Operating elements	Button
Bluetooth	Interface	yes
Protection class	Protection against contact, dust and splash water	IP 54
Tyres	Pneumatic tyres with inch hoses	10
	Manufacturer	CHAOYANG
Operating temperature	in ° Celsius	-10 to +40
Set-down temperature	in ° Celsius	-20 to +45
Long-term storage temperature	in ° Celsius	+10 to +15
Battery level during long-term storage	in %	between 40 and 50

**CE-KONFORMITÄTSERKLÄRUNG**



Der nachstehende Hersteller/Alleinvertriebsberechtigte Inverkehrbringer

**Daten:** comscoot GmbH  
FN: 569864k  
UID: ATU77595826

ist verantwortlich für das folgende Produkt und die technischen Unterlagen

**Marke:** comscoot performance  
**Typ:** Elektrokleinstfahrzeug  
**Kategorie:** Selbstbalancierende Fahrzeuge – Elektrotretroller  
**Produktionsjahr:** ab 2022



Für das Produkt wird bestätigt, dass es den zum Zeitpunkt der Erklärung geltenden Anforderungen der folgenden europäischen Richtlinien entspricht:

- Maschinenrichtlinie gemäß 2006/42/EG
- Richtlinie über elektromagnetische Verträglichkeit 2014/30/EU
- Beschränkung der Verwendung bestimmter gefährlicher Stoffe in Elektro und Elektronikgeräten (RoHS) gemäß 2015/863

Folgende Normen oder technische Spezifikationen sind so weit anwendbar zur Anwendung gelangt:

- EN 61000-6-1:2007
- EN 61000-6-3:2007+A1:2011
- EN 60950-1:2006+A11+A1+A12+A2
- EN 61558-2:2005+A1
- EN 61558-2-16:2009+A1
- IEC 62133:2012
- UN 38.3
- DIN EN 15194:2018-11
- UN ECE – R 10

Bevollmächtigter und verantwortlich für die Zusammenstellung:

 <p><b>comscoot</b> commute and scoot comscoot GmbH AT-8403 Lebring, Südbahnweg 17-19 FN: 569864k, UID: ATU77595826</p>	 <p><b>comscoot</b> commute and scoot comscoot GmbH AT-8403 Lebring, Südbahnweg 17-19 FN: 569864k, UID: ATU77595826</p>
<p><b>Philipp Oswald, CEO</b></p>	<p><b>Georg Schnabel, CEO</b></p>

Lebring, 31.12.2021

EN

## comscoot GmbH

Südbahnweg 17-19 TOP 2

8403 Lebring

Telefon: +43(0)664 750 620 50

+43(0)664 47 90 802

E-Mail: [info@comscoot.com](mailto:info@comscoot.com)

Web: [www.comscoot.com](http://www.comscoot.com)

These operating instructions correspond to the technical and legal status in February 2022.



comscot  
commute and scoot

[www.comscot.com](http://www.comscot.com)